

Low Profile Programmable Thermocouple or RTD Signal Conditioners Offer Improved Accuracy and Reliability

The SERIES 5750 temperature transmitter from Watlow® offers remarkably accurate temperature measurement and improves reliability to reduce downtime and costs.

The SERIES 5750 offers new measurements with resistance temperature detectors (RTDs) in three- and four-wire connections. It is designed to fit directly inside connection heads type DIN B or larger.

The transmitter is programmed using a separate connection cable and an easy-to-use Windows®-based software program configures the transmitter in seconds.

The SERIES 5750 provides linearization between temperature sensor input signals and the 4-20mA output signal to ensure accurate temperature measurements across a broad range.

Contact Watlow's customer service department to integrate this transmitter into a Watlow Style AR or AT thermocouple sensor or with a Style RR or RT RTD sensor.



Features and Benefits

Accepts three- and four-wire RTD and thermocouple sensor inputs

- Standardizes transmitter for various sensors and applications

Designed for harsh conditions

- Withstands high vibration and high humidity applications

Sensor error compensation function

- Provides convenience for adjusting the sensor/transmitter combination, or the transmitter alone, ensuring accurate temperature measurement within a specific range

Large center hole and robust terminals with test connections and low height

- Enables easy mounting

Configuration without external power

- Allows configurations to be edited or read offline by connecting to a personal computer (PC) universal serial bus (USB) port

Easy-to-use Windows® configuration software

- Parameters such as sensor type, measuring range, filter activation, cold junction compensation, sensor failure and error corrections are set in one window

Specifications

Input RTD

- Pt100 (IEC 60751, $\alpha = 0.00385$)
-328 to +1832°F (-200 to +1000°C)
- Pt100 (JIS C 1604, $\alpha = 0.003916$)
-328 to +1832°F (-200 to +1000°C)
- Pt1000 (IEC 60751, $\alpha = 0.00385$)
-328 to +392°F (-200 to +200°C)
- 3-, 4-wire connection
- Sensor current ~ 0.4mA
- Max. sensor wire resistance 25Ω/wire

Input Thermocouples

- Range Type: B, C, E, J, K, N, R, S, T
- Max. sensor wire resistance 500Ω (total loop)

Monitoring

- Sensor failure monitoring upscale or downscale action

Adjustments

- Zero adjustments for all inputs at any value within temperature range limits
- Min. spans: Pt input 18°F (10°C)
T/C 2mV

Output

- Analog 4-20mA, temperature linear
- Resolution 5μA
- Min. output signal measurement/failure 3.8mA/3.5mA
- Max. output signal measurement/failure 20.5mA/21.6mA
- Permissible load, see load diagram 725Ω @ 24VDC

Temperature

- Ambient, storage and operation
-40 to +185°F (-40 to +85°C)

General Data

- Selectable dampening time ~ 2s
- Update time ~ 1.5s
- Isolation in - out non-isolated
- Humidity 0 to 100% RH
- Vibration acc. to IEC 60068-2-6, test Fc,
60-500Hz, 10g
- Output limitations and fail currents are NAMUR compliant

Power Supply

- Polarity protected
- Supply voltage 8 to 32VDC
- Permissible ripple 4V p-p @ 50/60Hz

Accuracy

- Linearity RTD $\pm 0.1\%$ ^①
T/C $\pm 0.2\%$ ^①
- Calibration RTD max. of $\pm 0.4^\circ\text{F}$ / $\pm 0.2^\circ\text{C}$ or $\pm 0.1\%$ ^①
T/C max. of $\pm 20\mu\text{V}$ or $\pm 0.1\%$ ^①
- Cold junction compensation (CJC) T/C $\pm 0.9^\circ\text{F}$ ($\pm 0.5^\circ\text{C}$)
- Temperature influence^③ All inputs max. of $\pm 0.25^\circ\text{C}/25^\circ\text{C}$ or $\pm 0.25\%/25^\circ\text{C}$ ^{① ②}
- Max. of $\pm 0.5^\circ\text{F}/50^\circ\text{F}$ or $\pm 0.28\%/50^\circ\text{F}$ ^{① ②}

Housing

- Material, Flammability (UL[®]) PC/ABS + PA, V0
- Mounting DIN B-head or larger, DIN rail (with mounting kit)
- Connection single/stranded wires max. 1.5 mm², AWG 16
- Weight 32g
- Protection, housing / terminals IP 65/IP 00

① Of input span

② If zero-deflection >100% of input span: add 0.125% of input span/25°C or 0.14% of input span/50°F per 100% zero-deflection

③ Reference temperature 68°F (20°C)

Input Connections

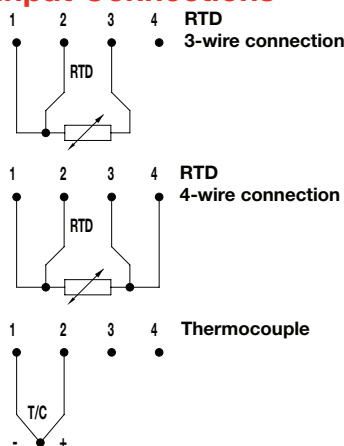

Output Connections

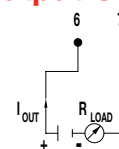

Dimensional Drawing

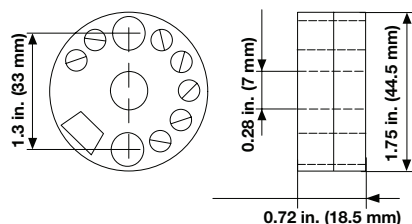

Ordering Information

Part Number

1 2 3 4	5	6	7 8 9	10	11 12 13 14	15
SERIES	Sensor Type	Low Temp. Sign	Low Temp.	High Temp. Sign	High Temp.	Unit of Measure
5750						

1 2 3 4	SERIES
5750 =	Linearized T/C or RTD

5	Sensor Type
B =	Type B T/C
C =	Type C T/C
E =	Type E T/C
J =	Type J T/C
K =	Type K T/C
N =	Type N T/C
R =	Type R T/C
S =	Type S T/C
T =	Type T T/C
0 =	PT100 (IEC 60751, $\alpha = 0.00385$) 3-wire
1 =	PT100 (JIS C 1604, $\alpha = 0.003916$) 3-wire
2 =	PT100 (IEC 60751, $\alpha = 0.00385$) 4-wire
3 =	PT100 (JIS C 1604, $\alpha = 0.003916$) 4-wire
4 =	PT1000 (IEC 60751, $\alpha = 0.00385$) 3-wire
5 =	PT1000 (IEC 60751, $\alpha = 0.00385$) 4-wire

6	Low Temperature Sign
	Enter + or - sign

7 8 9	Low Temperature
	Enter lowest limit temperature required

10	High Temperature Sign
	Enter + or - sign

11 12 13 14	High Temperature
	Enter higher limit temperature required

15	Unit of Measure
	Enter °F or °C

Program cable and software part #5750-CABLE (required for optional future changes)

Note: All accessories are subject to minimum purchase quantities.

Watlow® is a registered trademark of Watlow Electric Manufacturing Company.
Windows® is a registered trademark of Microsoft Corporation.
UL® is a registered trademark of Underwriter's Laboratories, Inc.

To be automatically connected to the nearest North American Technical Sales Office:
1-800-WATLOW2 • www.watlow.com • inquiry@watlow.com

International Technical Sales Offices: Australia, +61 3 9335 6449 • China, +86 21 3532 8532 • France, +33 1 41 32 79 70
Germany, +49 (0) 72 53 / 94 00-0 • India, +91 40 6661 2700 • Italy, +39 024588841 • Japan, +81 3 3518 6630 • Korea, +82 2 2628 5770
Malaysia, +60 3 8076 8745 • Mexico, +52 442 217 6235 • Singapore, +65 6773 9488 • Spain, +34 91 675 12 92
Taiwan, +886 7 288 5168 • United Kingdom, +44 (0) 115 964 0777