

General Specifications

Model FLXA202 2-Wire Analyzer

GS 12A01A03-01EN

■ General

The model FLXA™202 2-Wire Analyzer, one model of FLEXA™ series, offers single or dual sensor measurement. The modular-designed analyzer offers 4 kinds of measurements – pH/ORP (oxidation-reduction potential), contacting conductivity (SC), inductive conductivity (ISC) or dissolved oxygen (DO) – with the respective sensor module.

For dual sensor measurement, the combination of two same type sensor inputs – pH/ORP and pH/ORP (analog sensor only), SC and SC, and DO and DO – are available with two sensor modules. Dual sensor measurement offers additional functionalities; calculated data function and redundant system.

Variety of calculated data from two measuring parameters is selectable for each measurement. On the redundant system built on two measuring parameters of two sensor inputs, main output parameter is automatically switched over to the second sensor output in case of the main sensor's failure condition.

In addition to conventional analog pH/ORP sensors, the analyzer FLXA202 can be connected to Yokogawa's digital sensor, FU20F / FU24F / SC25F Digital pH/ORP SENCOM™ Sensor.

In the FLXA202 Human Machine Interface (HMI), 2-wire type analyzer FLXA202 offers easy touch screen operation and simple menu structure in 12 languages. Menus of display, execution and setting are displayed in a selected language.

The analyzer FLXA202 automatically recognizes the installed sensor module and prepares the necessary menus for right configuration, even for dual sensor measurement.

For immediate measurement, the FLXA202 offers quick setup functionality. The quick setup screen appears when the analyzer is powered. Only a few setups – date/time, language, basic sensor configurations and output – will start the measurement.

The FLXA202 offers the best accuracy in measurement with temperature compensation functionality and calibration functionality. Sensor diagnostics and sensor wellness indication make measurement reliable. Logbook of events and diagnostic data is a useful information source for maintenance.

For the wide range of industrial environment, the FLXA202 is designed with the enclosure of aluminum alloy cast with corrosion-resistant coating.

FLEXA, FLXA, SENCOM are trademarks or registered trademarks of Yokogawa Electric Corporation. All other company and product names mentioned in this document are trademarks or registered trademarks of their respective companies.

Please select appropriate equipment in accordance with the laws and regulations of the relevant country/region, when it is used in a location where explosive atmospheres may be present.



■ Features

- 4 kinds of measurements; pH/ORP, SC, ISC and DO
- Dual sensor measurement on 2-wire type analyzer; pH/ORP and pH/ORP, SC and SC, and DO and DO
- Calculated data from dual sensor measurement
- Redundant system on dual sensor measurement
- Connection of FU20F / FU24F / SC25F Digital pH/ORP SENCOM Sensor
- Easy touch screen operation on 2-wire type analyzer
- Simple HMI menu structure in 12 languages
- Quick setup menu for immediate measurement
- Indication of sensor wellness
- Enclosure – aluminum alloy cast.

■ General Specifications

1. Basic

■ Measurement Object/Sensor Type

- pH/Oxidation-reduction Potential (pH/ORP) (analog sensor)
- Conductivity (SC)
- Inductive Conductivity (ISC)
- Dissolved Oxygen (DO)
- pH/Oxidation-reduction Potential (pH/ORP) (digital sensor)

Note: The available measurement object depends on a sensor module installed on the analyzer.

■ Analyzer Structure

Module structure

● Composition of Analyzer

- One (1) Housing assembly
- One (1) or two (2) Sensor modules

● Combination of Sensor Module when two modules are installed

- Combinations of two same sensor modules are available;
- pH/ORP and pH/ORP (analog sensor)
 - SC and SC
 - DO and DO

2. Measurement

2-1. pH/Oxidation-reduction Potential (pH/ORP) with analog sensors

■ Input Specification

Dual high impedance input ($\geq 10^{12} \Omega$)

■ Input Range

pH: -2 to 16 pH (with option /K: 0 to 14 pH)
 ORP: -1500 to 1500 mV
 rH: 0 to 100 rH

Temperature:

Pt1000: -30 to 140 °C
 Pt100: -30 to 140 °C
 6.8k: -30 to 140 °C
 PTC10k: -30 to 140 °C
 NTC 8k55: -10 to 120 °C
 3k Balco: -30 to 140 °C
 PTC500: -30 to 140 °C

■ Output Range

pH: min. span 1 pH
 max. span 20 pH
 ORP: min. span 100 mV
 max. span 3000 mV
 rH: min. span 2 rH
 max. span 100 rH
 Temperature: min. span 25 °C
 max. span 170 °C

■ Performance (Accuracy)

(The specifications are expressed with simulated inputs.)

pH

Linearity: ± 0.01 pH
 Repeatability: ± 0.01 pH
 Accuracy: ± 0.01 pH

ORP

Linearity: ± 1 mV
 Repeatability: ± 1 mV
 Accuracy: ± 1 mV

Temperature

with Pt1000, 6.8k, PTC10k, NTC 8k55, 3k Balco, PTC500

Linearity: ± 0.3 °C
 Repeatability: ± 0.1 °C
 Accuracy: ± 0.3 °C

with Pt100

Linearity: ± 0.4 °C
 Repeatability: ± 0.1 °C
 Accuracy: ± 0.4 °C

2-2. Conductivity (SC)

■ Input Specification

Two or four electrodes measurement with square wave excitation, using max 60m (200ft) cable (WU40/WF10) and cell constants from 0.005 to 50.0 cm^{-1}

■ Input Range

Conductivity:

min.: 0 $\mu\text{S}/\text{cm}$
 max.: 200 mS x (Cell constant)
 (over range 2000 mS/cm)

Resistivity:

min.: 0.005 $\text{k}\Omega$ / (Cell constant)
 max.: 1000 $\text{M}\Omega$ x cm

Temperature:

Pt1000: -20 to 250 °C
 Pt100: -20 to 200 °C
 Ni100: -20 to 200 °C
 NTC 8k55: -10 to 120 °C
 Pb36(JIS NTC 6k): -20 to 120 °C

■ Output Range

Conductivity:

min. 0.01 $\mu\text{S}/\text{cm}$
 max. 2000 mS/cm (max 90% zero suppression)

Resistivity:

min. 0.001 $\text{k}\Omega$ x cm
 max. 1000 $\text{M}\Omega$ x cm (max 90% zero suppression)

Temperature:

min. span 25 °C
 max. span 270 °C

■ Performance (Accuracy)

(The specifications are expressed with simulated inputs.)

Conductivity

2 μS x K cm^{-1} to 200 mS x K cm^{-1}
 Accuracy: $\pm 0.5\%$ F.S.
 1 μS x K cm^{-1} to 2 μS x K cm^{-1}
 Accuracy: $\pm 1\%$ F.S.

Resistivity

0.005 $\text{k}\Omega$ / K cm^{-1} to 0.5 $\text{M}\Omega$ / K cm^{-1}
 Accuracy: $\pm 0.5\%$ F.S.
 0.5 $\text{M}\Omega$ / K cm^{-1} to 1 $\text{M}\Omega$ / K cm^{-1}
 Accuracy: $\pm 1\%$ F.S.

Temperature

with Pt1000, Pb36, Ni100
 Accuracy: ± 0.3 °C
 with Pt100, NTC 8k55
 Accuracy: ± 0.4 °C

Temperature compensation

NaCl table: ± 1 %
 Matrix: ± 3 %

Step response: 90 % (< 2 decades) in 7 seconds

Note: "F.S." means maximum setting value of analyzer output.
 "K" means cell constant.

YOKOGAWA provides conductivity sensors of which cell constants are 0.1 to 10 cm^{-1} .

2-3. Inductive Conductivity (ISC)

■ Input Specification

Compatible with the Yokogawa inductive conductivity ISC40 series with integrated temperature sensor: NTC30k or Pt1000.

■ Input Range

Conductivity: 0 to 2000 mS/cm at 25 °C reference temperature.

Temperature: -20 to 140 °C

Cable length:

max. 60 meters total length of fixed sensor cable + WF10(J) extension cable.

Influence of cable can be adjusted by doing an AIR CAL with the cable connected to a dry cell.

■ Output Range

Conductivity:

min. span: 100 μ S/cm

max. span: 2000 mS/cm (max 90% zero suppression)

Temperature:

min. span 25 °C

max. span 160 °C

■ Performance (Accuracy)

(The specifications are expressed with simulated inputs.)

(Output span is 0-100 μ S/cm or more)

Conductivity:

Linearity: $\pm(0.4 \%F.S. + 0.3 \mu S/cm)$

Repeatability: $\pm(0.4 \%F.S. + 0.3 \mu S/cm)$

Temperature: ± 0.3 °C

Step response: 90 % (< 2 decades) in 8 seconds

Note: "F.S." means maximum setting value of analyzer output.

2-4. Dissolved Oxygen (DO)

■ Input Specification

The FLXA202 accepts output from membrane covered Dissolved Oxygen sensors. These sensors can be Galvanic type, where the sensor generates its own driving voltage or Polarographic type, where the sensor uses external driving voltage from the converter.

The input range is 0 to 50 μ A for Galvanic sensors and 0 to 1 μ A for Polarographic sensors.

For temperature compensation, the FLXA202 accepts Pt1000 (DO30 sensor) and NTC22k elements (OXYFERM and OXYGOLD sensors).

■ Input Range

Dissolved Oxygen: 0 to 50 mg/l (ppm)

Temperature: -20 to 150 °C

DO30G sensor:

Measurement range: 0 to 20 mg/l (ppm)

Temperature: 0 to 40 °C

Hamilton sensors:

Oxyferm:

Measurement range: 10 ppb to 40 ppm

Temperature range: 0 to 130 °C

Oxygold G:

Measurement range: 2 ppb to 40 ppm

Temperature range: 0 to 130 °C

Oxygold B:

Measurement range: 8 ppb to 40 ppm

Temperature range: 0 to 100 °C

■ Output Range

DO concentration:

mg/l (ppm):

min.: 1 mg/l (ppm)

max.: 50 mg/l (ppm)

ppb:

min.: 1 ppb

max.: 9999 ppb

% saturation:

min.: 10 %

max.: 600 %

Temperature:

min. span 25 °C

max. span 170 °C

■ Performance (Accuracy)

(The specifications are expressed with simulated inputs.)

Performance in ppm mode:

Linearity: ± 0.05 ppm or $\pm 0.8\%$ F.S., whichever is greater

Repeatability: ± 0.05 ppm or $\pm 0.8\%$ F.S., whichever is greater

Accuracy: ± 0.05 ppm or $\pm 0.8\%$ F.S., whichever is greater

Performance in ppb mode:

Linearity: ± 1 ppb or $\pm 0.8\%$ F.S., whichever is greater

Repeatability: ± 1 ppb or $\pm 0.8\%$ F.S., whichever is greater

Accuracy: ± 1 ppb or $\pm 0.8\%$ F.S., whichever is greater

Temperature

Linearity: ± 0.3 °C

Repeatability: ± 0.1 °C

Accuracy: ± 0.3 °C

Note: "F.S." means maximum setting value of analyzer output.

2-5. pH/Oxidation-reduction Potential (pH/ORP) with digital sensor, FU20F pH/ORP SENCOR Sensor

■ Input Specification

Bi-directional digital communication (RS-485) between FU20F and FLXA202

■ Input Range (depending on FU20F)

pH: 0 to 14 pH

ORP: -1500 to 1500 mV

rH: 0 to 100 rH

Temperature: -10 to 105 °C

■ Output Range

pH: min. span 1 pH

max. span 20 pH

ORP: min. span 100 mV

max. span 3000 mV

rH: min. span 2 rH

max. span 100 rH

Temperature: min. span 25 °C

max. span 170 °C

3. Electrical

■ Output Signal

General: One output of 4-20 mA DC
 Note: Tolerance: ± 0.02 mA
 Bi-directional HART digital communication, superimposed on mA (4-20mA) signal

Output function:

Linear or Non-linear (21-step table)

Burn out function: (NAMUR 43 except ISC)

Without HART/PH201G:

Down: 3.6 mA
 (signal: 3.8 to 20.5 mA for pH/ORP, SC and DO)

(signal: 3.9 to 20.5 mA for ISC)

Up: 22mA

With HART/PH201G:

Down: 3.6 mA for pH/ORP, SC and DO

Down: 3.9 mA for ISC

(signal: 3.8 to 20.5 mA for pH/ORP, SC and DO)

(signal: 3.9 to 20.5 mA for ISC)

Up: 22mA

■ Power Supply

Nominal 24 V DC loop powered system

One (1) Sensor module (1 input):

16 to 40V DC (for pH/ORP (analog sensor), SC and DO)

17 to 40V DC (for ISC)

21 to 40V DC (for pH/ORP SENCOM sensor)

Two (2) Sensor modules (2 inputs):

22.8 to 40V DC (for pH/ORP (analog sensor), SC and DO)

Note: When the FLXA202 is used in the multi-drop mode of HART communication, the output signal is changed from 12.5 mA DC to 4 mA DC just after the power is turned on. Enough power supply for the instruments is to be provided.

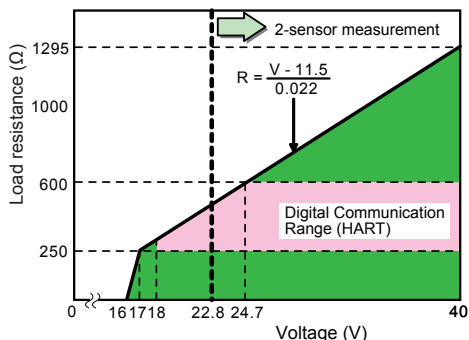

Figure 1 Supply Voltage and Load Resistance for pH/ORP (analog sensor), SC and DO

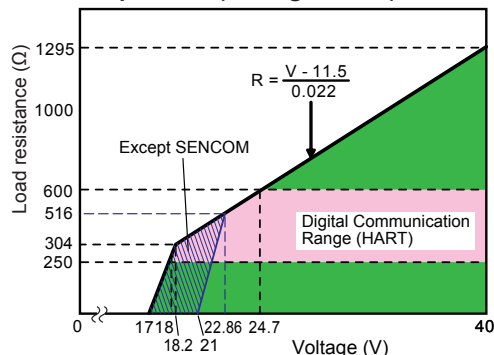

Figure 2 Supply Voltage and Load Resistance for ISC and pH/ORP SENCOM sensor

● Maximum Load Resistance

pH/ORP (analog sensor), SC and DO:

Refer to the Figure 1.

ISC and pH/ORP SENCOM sensor:

Refer to the Figure 2.

■ Display

LCD with a touch screen:

Black/White: 213 x 160 pixels

Contrast adjustment available on the touch screen

Message language:

12 (English, Chinese, Czech, French, German, Italian, Japanese, Korean, Polish, Portuguese, Russian and Spanish)
 One analyzer has all 12 languages.

Note: Description for a selection of language and language names are written in English.

Note: Only English alphabet and numeric are available for a tag number, an additional description for each value on the display screen and passwords.

Note: Only for message language on the screen, 12 languages are provided.

4. Mechanical and others

■ Housing

Case, Cover:

- Aluminum alloy cast + epoxy coating
- Aluminum alloy cast + urethane coating
- Aluminum alloy cast + high anti-corrosion coating

Color: Silver gray

Protection: IP66 (except Canada), NEMA Type 4X (USA), CSA Type 3S/4X (Canada)

■ Cable and Terminal

Cable size:

Outer diameter:

6 to 12 mm (suitable for M20 cable gland)

Terminal screw size: M4

torque of screw up: 1.2 N•m

Wire terminal:

Pin terminal, ring terminal and spade terminal can be used for analyzer's power supply terminals and sensor terminals.

Grounding terminal:

Ring terminal should be used.

Pin terminal: pin diameter: max. 1.9 mm

Ring and spade terminal: width: max. 7.8 mm

■ Cable Entry

3 holes,

M20 cable gland x 3 pcs

Close up plug x 1 pc

Note: Cable gland and plug are delivered with an analyzer, but not assembled into the analyzer.

■ Mounting

Mounting hardware (option):

- Universal mounting kit (Note)
- Pipe and wall mounting hardware
- Panel mounting hardware

Note: This kit contains the pipe and wall mounting hardware and the panel mounting hardware.

Hood (option):

- Stainless steel
- Stainless steel with urethane coating
- Stainless steel with epoxy coating

■ Stainless Steel Tag Plate

When the additional code "/SCT" with a tag number is specified, the tag plate on which the tag number is inscribed is delivered with the analyzer.

Tag plate is hanging type.

■ Conduit Adapter

Using optional adapter

- G1/2 (quantity: 3)
- 1/2NPT (quantity: 3)
- M20 x 1.5 (quantity: 3)

These conduit adapters are delivered with an analyzer, but not assembled into the analyzer.

■ Size of Housing Case

165 x 165 x 155 mm (W x H x D) (without cable gland)

■ Weight

Approx. 2.5 kg

■ Ambient Operating Temperature

-20 to +55 °C

■ Storage Temperature

-30 to +70 °C

■ Humidity

10 to 90% RH at 40°C (Non-condensing)

■ Document

Following documents are delivered with an analyzer;

Paper copy:

Start-up Manual

written in English

Safety Precautions

written in English

CD-ROM:

Start-up Manual

written in English

User's Manual

written in English

Safety Regulations Manual

for European region

written in 25 languages

General Specifications

written in English

Technical Information

for HART Communication

written in English

User Setting Table

of 5 kinds of measurement/sensor type

written in English

5. Digital Communication

■ Kind of Digital Communication

- HART (HART 5) or PH201G dedicated distributor
Note: Only one kind of digital communication is available for one analyzer.

■ Output Value Parameter (HART)

Four value parameters (measured values) are available for one digital communication.

- For 1-sensor measurement, these parameters are measured values.
- For 2-sensor measurement, refer to the next item.

■ Digital Communication of 2-Sensor Measurement (HART)

Even when two sensor modules are installed, only one digital communication is available for 2-sensor measurement.

Four value parameters can be selected from the followings;

Measured values of two sensors

Calculated data of 2-sensor measurement

Redundant system output

■ Specific Contact Output with dedicated distributor, model PH201G (Style B)

The distributor, model PH201G, is designed to connect with the 2-Wire Analyzer.

This distributor supplies drive power to the analyzer and receives simultaneously 4-20 mA DC signal from the analyzer.

This signal is converted to 1-5 V DC signal in the distributor.

This distributor also receives digital signals superimposed on the 4-20 mA DC signal, and provides contact outputs

Input/Output signal:

Number of available drive/signal point: 1

Output signal: 1-5 V DC (2 points) (Note)

Load resistance: 2 kΩ or less (1-5 V DC output)

Isolation system: Loop isolation type

Note: Two output signals for one analyzer's analog output are provided. Two 1-5 V DC output signals are same.

Contact output:

Contact rating:

250 V AC, maximum 100 VA

220 V DC, maximum 50 VA

Hold contact output:

NC contact, normally energized

Contact closes when power is off or during Hold situation.

Fail contact output:

NC contact, normally energized

Contact closes when power is off or during Fail/Warning conditions.

Wash contact output:

NO contact

Contact closes during wash cycles.

■ Regulatory Compliance (FLXA202)

■ Safety, EMC and RoHS Compliance

- Safety: UL 61010-1
 UL 61010-2-030
 CAN/CSA-C22.2 No.61010-1
 CAN/CSA-C22.2 No.61010-2-030
 EN 61010-1
 EN 61010-2-030
- EMC: EN 61326-1 Class A, Table 2 (For use in industrial locations)
 EN 61326-2-3
 RCM: EN 61326-1 Class A, Table 2
 Korea Electromagnetic Conformity Standard Class A 한국 전자파적합성 기준
 Russian: TR CU 020/2011
- RoHS: EN 50581: 2012 (Style 1.02 or newer)
 Installation altitude: 2000 m or less
 Category based on IEC 61010: I (Note 1)
 Pollution degree based on IEC 61010: 2 (Note 2)
- Note 1: Installation category, called over-voltage category, specifies impulse withstand voltage. Equipment with "Category I" (ex. two wire transmitter) is used for connection to circuits in which measures are taken to limit transient over-voltages to an appropriately low level.
- Note 2: Pollution degree indicates the degree of existence of solid, liquid, gas or other inclusions which may reduce dielectric strength. Degree 2 is the normal indoor environment.
- Information of the WEEE Directive
 This product is purposely designed to be used in a large scale fixed installations only and, therefore, is out of scope of the WEEE Directive. The WEEE Directive does not apply. The WEEE Directive is only valid in the EU.

■ Explosion Protected Type Compliance

Item	Description	'Type' in MS code
Europe (ATEX)	[Intrinsic safety "ia"] Applicable Standard: EN 60079-0: 2012 + A11: 2013, EN 60079-11: 2012 Certificate No: DEKRA 11ATEX0109X Marking/Rating: Ex II 1 G Ex ia IIC T4 Ga Ambient Temperature: -20 to 55°C Control Drawing: Refer to (1)	-CB
International (IECEX)	[Intrinsic safety "ia"] Applicable Standard: IEC 60079-0: 2011, IEC 60079-11: 2011 Certificate No: IECEX DEK 11.0044X Marking/Rating: Ex ia IIC T4 Ga Ambient Temperature: -20 to 55°C Control Drawing: Refer to (1)	
United States (FM)	[Intrinsically safe / Nonincendive] Applicable Standard: Class 3600: 2011, Class 3610: 2010, Class 3611: 2004, Class 3810:2005, NEMA 250: 2014, ANSI/ISA 60079-0: 2013, ANSI/ISA 60079-11: 2014 Certificate No: 3039632 Marking/Rating: IS CL I, DIV 1, GP ABCD CL I, ZN 0, AEx ia IIC NI CL I, DIV 2, GP ABCD CL I, ZN 2 IIC T4: for ambient temperature: -20 to 55°C Enclosure: Type 4X Control Drawing: Refer to (3)	-CD
Canada (CSA)	[Intrinsically safe / Nonincendive] Applicable Standard: C22.2 No.0-10 (R2015), CAN/CSA-C22.2 No.94-M91 (R2011), C22.2 No.213-M1987 (R2013), CAN/CSA-C22.2 No.60079-0:11, CAN/CSA-C22.2 No.60079-11:14, CAN/CSA-C22.2 No.61010-1-12, CAN/CSA-C22.2 No.61010-2-030-12 Certificate No: 2425510 Marking/Rating: Ex ia IIC T4 Ga Intrinsically safe for Class I, Division 1, Groups A, B, C, D, T4 Nonincendive for Class I, Division 2, Groups A, B, C, D, T4 Ambient Temperature: -20 to 55°C Ambient Humidity: 0 – 100% (No Condensation) Enclosure: IP66, NEMA 4X Control Drawing: Refer to (2)	

Item	Description	'Type' in MS code
United States (FM)	[Nonincendive] Applicable Standard: Class 3600: 2011, Class 3611: 2004, Class 3810: 2005, NEMA 250: 2014 Certificate No: 3039632 Marking/Rating: NI CL I, DIV 2, GP ABCD ZN 2 IIC T4: for ambient temperature: -20 to 55°C Enclosure: Type 4X Control Drawing: Refer to (3)	-DD
Canada (CSA)	Applicable Standard: C22.2 No.0-10 (R2015), CAN/CSA-C22.2 No.94-M91 (R2011), C22.2 No.213-M1987 (R2013), CAN/CSA-C22.2 No.61010-1-12, CAN/CSA-C22.2 No.61010-2-030-12 Certificate No: 2425510 Marking/Rating: Nonincendive for Class I, Division 2, Groups A, B, C, D, T4 Ambient Temperature: -20 to 55°C Ambient Humidity: 0 – 100% (No Condensation) Enclosure: IP66, NEMA 4X Control Drawing: Refer to (2)	
Canada (CSA)	[Type of protection 'n' / Nonincendive] Applicable Standard: C22.2 No.0-10 (R2015), CAN/CSA-C22.2 No.94-M91 (R2011), C22.2 No.213-M1987 (R2013), CAN/CSA-C22.2 No.60079-0:11, CAN/CSA-C22.2 No.60079-11:14, CAN/CSA-C22.2 No.60079-15:12, CAN/CSA-C22.2 No.61010-1-12, CAN/CSA-C22.2 No.61010-2-030-12 Certificate No: 2425510 Marking/Rating: Ex nA ic IIC T4 Gc Nonincendive for Class I, Division 2, Groups A, B, C, D, T4 Ambient Temperature: -20 to 55°C Ambient Humidity: 0 – 100% (No Condensation) Enclosure: IP66, NEMA 4X Control Drawing: Refer to (2)	-DE

Item	Description	'Type' in MS code
Europe (ATEX)	[Type of protection 'n'] Certificate: Not Applicable as per Annex VIII to ATEX 2014/34/EU Applicable Standard: EN 60079-0: 2012 + A11:2013, EN 60079-11: 2012, EN 60079-15: 2010, EN 60529: 1991+A2:2013 Marking/Rating: Ⓔ II 3 G Ex nA ic IIC T4 Gc Ambient Temperature: -20 to 55°C Enclosure: IP66 Control Drawing: Refer to (4)	-DB
International (IECEX)	[Type of protection 'n'] Applicable Standard: IEC 60079-0: 2011, IEC 60079-11:2011, IEC 60079-15: 2010 Certificate No: IECEX DEK 16.0034X Marking/Rating: Ex nA ic IIC T4 Gc Ambient Temperature: -20 to 55°C Enclosure: IP66 Control Drawing: Refer to (5)	
China (NEPSI)	[Intrinsic safety "ia"] Applicable Standard: GB3836.1-2010, GB3836.4-2010, GB 3836.20-2010 Certificate No: GYJ18.1051X Marking/Rating: Ex ia IIC T4 Ga Ambient Temperature: -20 to 55°C Control Drawing: Refer to (6)	-CH
Korea (KOSHA)	[Intrinsic safety "ia"] Applicable Standard: Notice of Ministry of Labor No. 2016-54 Certificate No: 15-AV4BO-0160X Marking/Rating: Ex ia IIC T4 Ga Ambient Temperature: -20 to 55°C Control Drawing: Refer to (6)	-CG

■ Control Drawings
 (1) ATEX and IECEx Intrinsic safety “ia”

Model: FLXA21 /FLXA202

Date: February 19, 2010

11 Drawings
 11.1 Control Drawing (for 4-20mA Type)

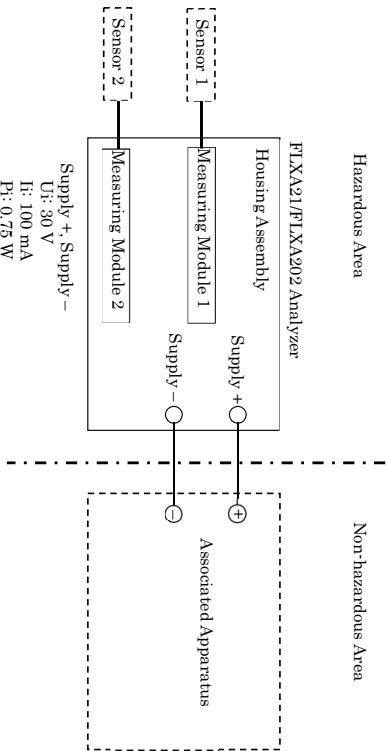

Supply +, Supply -
 Ui: 30 V
 Ii: 100 mA
 Pi: 0.75 W
 Ci: 13 nF
 Li: 0 mH

Measuring Module 1, 2

	Type of Measuring Module	
	pH, SG, DO	ISC
Uo	11.76 V	11.76 V
Io	116.5 mA	60.6 mA
Po	0.3424 W	0.178 W
Co	100 nF	100 nF
Lo	1.7 mH	8 mH

Rev.1: July, 25, 2016

Doc. No.: IKE039-A12 P.1

Yokogawa Electric Corporation

Model: FLXA21 /FLXA202

Date: Mar 24, 2013

Specific Conditions of Use

- When the enclosure of the Analyzer is made of aluminum alloy (FLXA202), and when the Analyzer used in an explosive atmosphere requiring equipment of Category 1 G or EPL Ga, it must be installed in such a way that, even in the event of rare incidents, an ignition source due to impact friction sparks is excluded.

- When accessing the display window or other non-metallic parts of the enclosure of FLXA202/FLXA21, take following measures to minimize the risk of explosion from electrostatic discharge.
 Also, avoid any actions that cause the generation of electrostatic charge, such as rubbing with a dry cloth.

- To avoid electrostatic charge on the operator,
 - Earth the operator through a wrist-strap, or
 - Operate FLXA202/FLXA21 on the conductive floors, wearing anti-static work clothes and electrostatic safety shoes, or
 - Neutralize the operator and FLXA202/FLXA21 by a static elimination bar which has a metal part earthed through resistor from 100KΩ to 100MΩ.

In case that those measures cannot be taken or static electricity cannot be suppressed, bring a gas detector and make sure there is no ignition capable atmosphere around FLXA202/FLXA21 before the operation.

Notes:

1. The associated apparatus must be a linear source.
2. Measuring Module 2 is not necessarily installed. As for ISC module and SENCOM module, only one module is permitted to be installed at a time.
3. Sensor 1 and Sensor 2 may be simple apparatus or intrinsically safe apparatus.
4. WARNING – POTENTIAL ELECTROSTATIC CHARGING HAZARD – SEE USER'S MANUAL

Rev.2: July, 25, 2016

Doc. No.: IKE039-A12 P.1-1

Yokogawa Electric Corporation

Model: FLXA21 / FLXA202

Date: May 29, 2017

Model: FLXA21 / FLXA202

Date: May 29, 2017

Control drawing (4-20mA type)

Installation for Zone 0, 1 / Division 1

Installation for Zone 2 / Division 2

Applicable models: FLXA21-D-x-x-CD-xx-xx-A...; FLXA202-D-x-x-CD-xx-xx-A...

Applicable models: FLXA21-D-x-x-CD-xx-xx-A...; FLXA21-D-x-x-DD-xx-xx-A...;
FLXA202-D-x-x-CD-xx-xx-A...; FLXA202-D-x-x-DD-xx-xx-A...;
FLXA202-D-x-x-DE-xx-xx-A...

Hazardous Area
Class I, Zone 0, 1, Group IIC, or
Class I, Division 1, Groups A, B, C, D
Temperature Class: T4

Non-hazardous Area

Hazardous Area
Class I, Zone 2, Group IIC, or
Class I, Division 2, Groups A, B, C, D
Temperature Class: T4

Non-hazardous Area

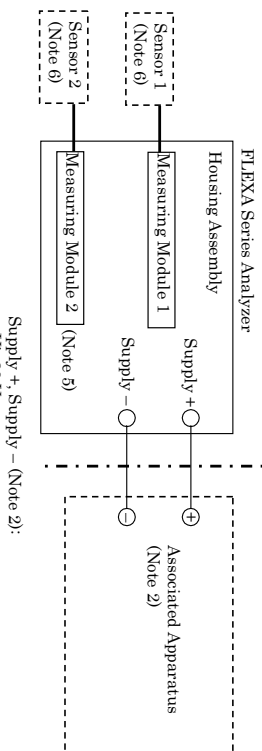

Supply +, Supply - (Note 2):
If: 100 mA
Uf: 30 V
Pi: 0.75 W
Cf: 13 nF
Lf: 0 mH

Measuring Module 1, 2 (Note 6):

Type of Measuring Module			
	pH, SC, DO	ISC	SENCOM
Uo	11.76 V	11.76 V	5.36 V
Io	116.5 mA	60.6 mA	106.16 mA
Po	0.3424 W	0.178 W	0.1423 W
Co	100 nF	100 nF	31 nF
Lo	1.7 mH	8 mH	0.45 mH

- Specific conditions of use
- Electrostatic charges on the non-metallic or coated parts of the two wire analyzer shall be avoided.
 - In the case where the enclosure of the analyzer is made of Aluminum, if it is mounted in Zone 0, it must be installed such, that even in the event of rare incidents, ignition sources due to impact and friction sparks are excluded.

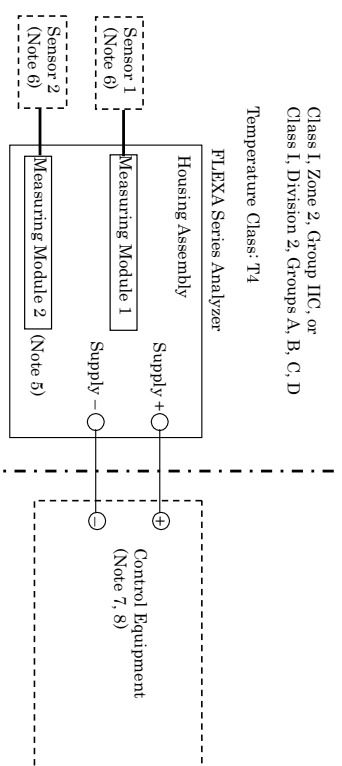

Supply +, Supply - (Note 7):
If: 30 V
Uf: 30 V
Pi: 0.75 W
Cf: 13 nF
Lf: 0 mH

Measuring Module 1, 2 (Note 6):

Type of Measuring Module			
	pH, SC, DO	ISC	SENCOM
Uo	11.76 V	11.76 V	5.36 V
Io	116.5 mA	60.6 mA	106.16 mA
Po	0.3424 W	0.178 W	0.1423 W
Co	100 nF	100 nF	31 nF
Lo	1.7 mH	8 mH	0.45 mH

- Specific condition of use
- Electrostatic charges on the non-metallic or coated parts of the two wire analyzer shall be avoided.
- Specific conditions of use for FLXA202-D-x-x-DE-xx-xx-A... when it is used as "Ex nA1c"
- The cable glands accompanying the equipment may not provide sufficient clamping. Additional clamping of the cable shall be provided to ensure that pulling and twisting are not transmitted to the termination. Alternatively, Ex d, Ex e, or Ex n cable glands which provide sufficient clamping shall be used instead of the accompanying cable gland.
 - The gaskets of the cable glands shall be protected from light.
 - Analyzer must be installed in such a way that the air vent is physically protected from any possible impact.

(2) CSA

Intrinsic safety, Nonincendive, Type of protection 'n'

Rev.

Doc. No.: ICS032-A71 P.1

Rev.

Doc. No.: ICS032-A71 P.2

Yokogawa Electric Corporation

Yokogawa Electric Corporation

Model: FLXA21 / FLXA202

Date: May 29, 2017

Model: FLXA21 / FLXA202

Date: May 29, 2017

Notes:

1. Installation must be in accordance with the Canadian Electric Code Part I (C22.1), ANSI/ISA-RP12.06.01 and relevant local codes.
2. The associated apparatus must be a linear source meeting the following conditions.
 - U_0 (or V_{oc}) $\leq U_i$
 - I_0 (or I_{sc}) $\leq I_H$
 - $P_0 \leq P_i$
 - C_0 (or C_d) $\geq C_i + C_{cable}$
 - L_0 (or L_d) $\geq L_i + L_{cable}$
3. Control equipment connected to the associated apparatus must not use or generate a voltage which exceeds U_m of the associated apparatus.
4. The control drawing of the associated apparatus must be followed when installing the equipment.
5. Measuring Module 2 is not always installed. As for ISC module and SENCOM module, only one module is permitted to be installed at a time.
6. When installed in Zone 0 or 1, or Division 1, Sensor 1 and Sensor 2 may be simple apparatus or intrinsically safe apparatus meeting the conditions below.
 - When installed in Zone 2 or Division 2, Sensor 1 and Sensor 2 may be simple apparatus or non-incendive field wiring apparatus meeting the conditions below, or alternatively, they may be equipment suitable for Zone 2 or Division 2 respectively, if a suitable wiring method other than non-incendive field wiring is employed.

$$U_i \text{ (or } V_{max}) \geq U_0$$

$$I_H \text{ (or } I_{max}) \geq I_0$$

$$P_i \geq P_0$$

$$C_i \leq C_0 - C_{cable}$$

$$L_i \leq L_0 - L_{cable}$$

7. The control equipment must be an associated non-incendive field wiring apparatus meeting the conditions below. Alternatively, it may be general-purpose equipment, if a suitable wiring method other than non-incendive field wiring is employed.

$$U_0 \text{ (or } V_{oc}) \leq U_i$$

$$C_0 \text{ (or } C_d) \geq C_i + C_{cable}$$

$$L_0 \text{ (or } L_d) \geq L_i + L_{cable}$$

8. When FLXA202-D-x-x-DE-xx-xx-A... is used as "Ex nA ic", it must be installed in accordance with one of the following:
 - a) in a SELV or PELV system, or
 - b) via a safety isolating transformer complying with the requirements of IEC 61558-2-6, or a technically equivalent standard, or
 - c) directly connected to apparatus complying with IEC60950 series, IEC61010-1, or a technically equivalent standard, or
 - d) fed directly from cells or batteries.
9. When FLXA202-D-x-x-DE-xx-xx-A... is used as "Ex nA ic" and with the accompanying cable glands, cable with an external diameter of 6 to 12 mm must be used for field wiring. The cable glands must be secured with a tightening torque of 6 Nm so that they can be released only with the aid of a tool. Unused cable gland shall be sealed with the accompanying metal plug.

10. WARNING – POTENTIAL ELECTROSTATIC CHARGING HAZARD
AVERTISSEMENT – DANGER POTENTIEL DE CHARGES ELECTROSTATIQUES
11. WARNING – SUBSTITUTION OF COMPONENTS MAY IMPAIR INTRINSIC SAFETY
AVERTISSEMENT – LA SUBSTITUTION DE COMPOSANTS PEUT COMPROMETTRE LA SÉCURITÉ INTRINSÈQUE.
12. WARNING – SUBSTITUTION OF COMPONENTS MAY IMPAIR SUITABILITY FOR ZONE 2 / DIVISION 2
AVERTISSEMENT – LA SUBSTITUTION DE COMPOSANTS PEUT RENDRE CE MATÉRIEL INACCEPTABLE POUR LES EMPLOIEMENTS DE ZONE 2 / DIVISION 2

Rev.

Doc. No.: ICS032-A71 P.3

Rev.

Doc. No.: ICS032-A71 P.4

Yokogawa Electric Corporation

Yokogawa Electric Corporation

Model: FLEXA Series

Date: April 17, 2015

Model: FLEXA Series

Date: April 17, 2015

Control drawing (4-20 mA type)

Installation for Division 1 / Zone 0_1

Installation for Division 2 / Zone 2

Applicable models: FLXA21-D-x-x-CD-xx-xx-A-..., FLXA202-D-x-x-CD-xx-xx-A-...

Applicable models: FLXA21-D-x-x-CD-xx-xx-A-..., FLXA21-D-x-x-DD-xx-xx-A-...; FLXA202-D-x-x-CD-xx-xx-A-..., FLXA202-D-x-x-DD-xx-xx-A-...

Hazardous (Classified) Location

Class I, Division 1, Groups A, B, C, D, or
Class I, Zone 0, 1, Group IIC

Unclassified Location

Hazardous (Classified) Location

Class I, Division 2, Groups A, B, C, D, or
Class I, Zone 2, Group IIC,

Unclassified Location

Temperature Class: T4

Temperature Class: T4

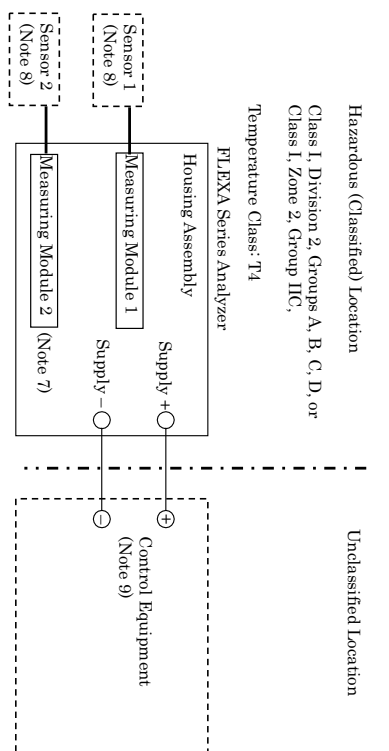
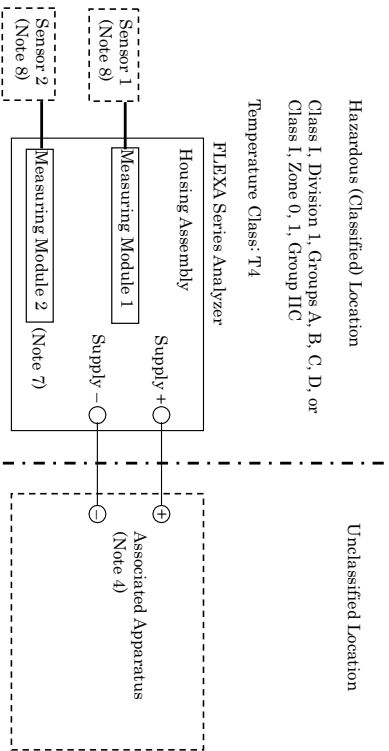

Measuring Module 1, 2 (Note 8):

Type of Measuring Module	
pH, SC, DO	ISENCOM
Uo	11.76 V
Io	116.5 mA
Po	0.3424 W
Co	100 nF
Lo	1.7 mH

Measuring Module 1, 2 (Note 8):

Type of Measuring Module	
pH, SC, DO	ISENCOM
Uo	11.76 V
Io	116.5 mA
Po	0.3424 W
Co	4 nF
Lo	4.5 mH

- Specific conditions of use:
- Electrostatic charges on the non-metallic or coated parts of the two wire analyzer shall be avoided.
 - In the case where the enclosure of the analyzer is made of Aluminum, if it is mounted in ZONE 0, it must be installed such that, even in the event of rare incidents, ignition sources due to impact and friction sparks are excluded.

- Specific condition of use:
- Electrostatic charges on the non-metallic or coated parts of the two wire analyzer shall be avoided.

Intrinsic safety, Nonincendive

(3) FM

Rev.1: May 29, 2017

Doc. No.: IFM039-A71 P.1

Rev.2: Sep. 15, 2017

Doc. No.: IFM039-A71 P.2

Yokogawa Electric Corporation

Yokogawa Electric Corporation

Model: FLEXA Series

Date: May 29, 2017

Notes:

1. This drawing replaces the former control drawing IKE039-A12.
2. No revision to this drawing without prior approval of FM.
3. Installation must be in accordance with the National Electric Code (NFPA 70), ANS/ISA-RP12.06-01 and relevant local codes.
4. The associated apparatus must be an FM-approved linear source meeting the following conditions:

$$\begin{aligned} U_0 \text{ (or } V_{oc}) &\leq U_i \\ I_0 \text{ (or } I_{sc}) &\leq I_i \\ P_0 &\leq P_i \\ C_0 \text{ (or } C_a) &\geq C_i + C_{cable} \\ L_0 \text{ (or } L_a) &\geq L_i + L_{cable} \end{aligned}$$

5. Control equipment connected to the associated apparatus must not use or generate a voltage which exceeds U_m of the associated apparatus.
6. The control drawing of the associated apparatus must be followed when installing the equipment.
7. Measuring Module 2 is not always installed. As for ISC module and SENCOM module, only one module is permitted to be installed at a time.
8. When installed in Division 1, Zone 0 or Zone 1, Sensor 1 and Sensor 2 may be simple apparatus or intrinsically safe apparatus meeting the conditions below.
When installed in Division 2 or Zone 2, Sensor 1 and Sensor 2 may be simple apparatus or nonincendive field wiring apparatus meeting the conditions below, or alternatively, they may be equipment suitable for Division 2 or Zone 2 respectively. If a suitable wiring method other than nonincendive field wiring is employed.

$$\begin{aligned} U_i \text{ (or } V_{max}) &\geq U_0 \\ I_i \text{ (or } I_{max}) &\geq I_0 \\ P_i &\geq P_0 \\ C_i &\leq C_0 - C_{cable} \\ L_i &\leq L_0 - L_{cable} \end{aligned}$$

9. The control equipment must be an FM-approved associated nonincendive field wiring apparatus meeting the conditions below. Alternatively, it may be general-purpose equipment, if a suitable wiring method other than nonincendive field wiring is employed.

$$\begin{aligned} U_0 \text{ (or } V_{oc}) &\leq U_i \\ C_0 \text{ (or } C_a) &\geq C_i + C_{cable} \\ L_0 \text{ (or } L_a) &\geq L_i + L_{cable} \end{aligned}$$

10. WARNING – POTENTIAL ELECTROSTATIC CHARGING HAZARD – WHEN THE EQUIPMENT IS USED IN HAZARDOUS LOCATIONS, AVOID ANY ACTION WHICH GENERATE ELECTROSTATIC DISCHARGE SUCH AS RUBBING WITH A DRY CLOTH.
11. WARNING – IN THE CASE WHERE THE ENCLOSURE OF THE ANALYZER IS MADE OF ALUMINUM, IF IT IS MOUNTED IN ZONE 0, IT MUST BE INSTALLED SUCH THAT EVEN IN THE EVENT OF RARE INCIDENTS, IGNITION SOURCES DUE TO IMPACT AND FRICTION SPARKS ARE EXCLUDED
12. WARNING – SUBSTITUTION OF COMPONENTS MAY IMPAIR INTRINSIC SAFETY AND SUITABILITY FOR DIVISION 2 / ZONE 2.

Rev.

Doc. No.: IFM039-A71 P.3

Yokogawa Electric Corporation

(4) ATEX (Type n) Type of protection 'n'

Model: FLXA202
 Control Drawing

Date: December 25, 2015

Model: FLXA202

Date: December 25, 2015

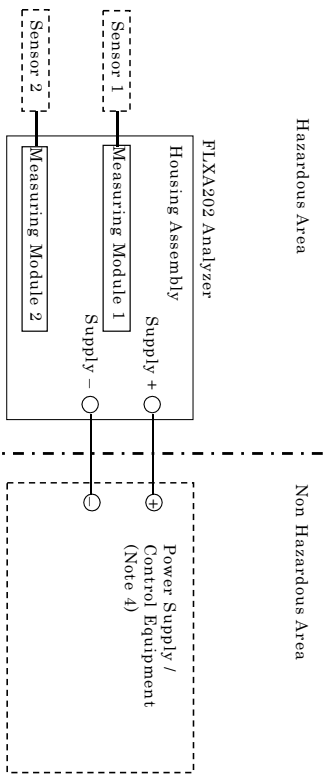

Ex nA.ie Ratings
 Supply +, Supply -
 Un: 29.6V
 Un: 16V to 29.6V (H/ORP,SC, DO one module)
 17V to 29.6V (ISC one module)
 21V to 29.6V (SENCOM one module)
 22.8V to 29.6V (PH/ORP,SC, DO two modules)

Measuring Module 1, 2

	Type of Measuring Module	
	PH, SC, DO	ISC
Uo	11.76 V	11.76 V
Io	116.5 mA	60.6 mA
Po	0.3424 W	0.178 W
Co	100 nF	100 nF
Lo	1.7 mH	8 mH
		0.45 mH

Specific condition of use
 - Electrostatic charges on the non-metallic or coated parts of the two wire analyzer shall be avoided.
 - The cable gland accompanying the equipment may not provide sufficient clamping. Additional clamping of the cable shall be provided to ensure that pulling and twisting are not transmitted to the termination. Alternatively, an Ex d, Ex e, or Ex n cable gland which provides sufficient clamping shall be used instead of the accompanying cable gland.
 - Analyzer must be installed in such a way that the air vent is physically protected from any possible impact.

Rev. 1: July 24, 2017

Doc.No.: NKE053-A71 P.1

Yokogawa Electric Corporation

Notes:

1. Installation must be in accordance with EN60079-14 and relevant local codes.
2. Measuring Module 2 is not always installed. As for ISC module and SENCOM module, only one module is permitted to be installed at a time.
3. When installed in an area where the use of Category 3 G equipment is required, Sensor 1 and Sensor 2 may be simple apparatus, intrinsically safe apparatus meeting conditions below, or other Category 3 G equipment.
 - U_i (or V_{max}) ≥ U_o
 - I_i (or I_{max}) ≥ I_o
 - P_i ≥ P_o
 - C_i ≤ C_o – Cable
 - L_i ≤ L_o – Cable
4. FLXA202 Analyzer must be installed in accordance with one of the following:
 - a) in a SELV or PELV system, or
 - b) via a safety isolating transformer complying with the requirements of IEC 61558-2-6, or a technically equivalent standard, or
 - c) directly connected to apparatus complying with IEC60950 series, IEC61010-1, or a technically equivalent standard, or
 - d) fed directly from cells or batteries.
5. When FLXA202 Analyzer is installed with accompanying cable glands, cable with an external diameter of 6 mm to 12 mm must be used for field wiring. The cable glands must be secured with a tightening torque of 6 Nm so that they can be released only with the aid of a tool. Unused cable gland shall be sealed with the accompanying metal plug.
6. The gaskets of the cable glands shall be protected from light.

Rev. 1: July 24, 2017

Doc.No.: NKE053-A71 P.2

Yokogawa Electric Corporation

Model: FLXA202 Date: March 31, 2016

Control Drawing

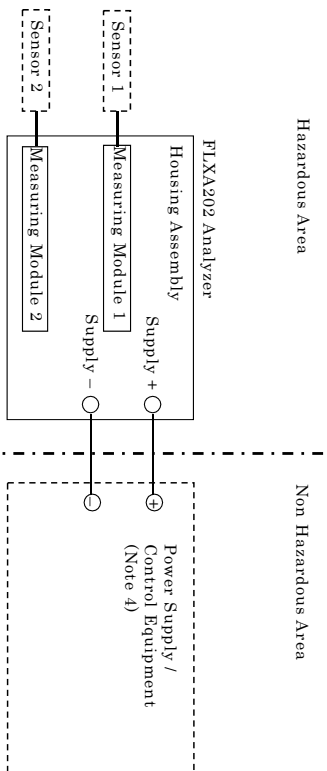

Ex nA ic Ratings
 Supply +, Supply -
 Um: 29,6V
 Un: 16V to 29,6V (pH/ORP,SC, DO one module)
 17V to 29,6V (ISC one module)
 21V to 29,6V (SENCOM one module)
 22,8V to 29,6V (pH/ORP,SC, DO two modules)

Measuring Module 1, 2

	Type of Measuring Module		
	pH, SC, DO	ISC	SENCOM
Uo	11,76 V	11,76 V	5,36 V
Io	116,5 mA	60,6 mA	106,16 mA
Po	0,3424 W	0,178 W	0,1423 W
Co	100 nF	100 nF	31 nF
Lo	1,7 mH	8 mH	0,45 mH

- Specific condition of use
- Electrostatic charges on the non-metallic or coated parts of the two wire analyzer shall be avoided.
 - The cable gland accompanying the equipment may not provide sufficient clamping. Additional clamping of the cable shall be provided to ensure that pulling and twisting are not transmitted to the termination. Alternatively, an Ex d, Ex e, or Ex n cable gland which provides sufficient clamping shall be used instead of the accompanying cable gland.
 - The gaskets of the cable glands shall be protected from light.
 - Analyzer must be installed in such a way that the air vent is physically protected from any possible impact.

Rev. Doc.No.: NIE015-A71 P.1

Yokogawa Electric Corporation

Model: FLXA202 Date: March 31, 2016

Notes:

1. Installation must be in accordance with IEC60079-14 and relevant local codes.
2. Measuring Module 2 is not always installed. As for ISC module and SENCOM module, only one module is permitted to be installed at a time.
3. When installed in an area where EPL Gc is required, Sensor 1 and Sensor 2 may be simple apparatus, intrinsically safe apparatus meeting conditions below, or other EPL Gc equipment.
 - Ui (or Vmax) ≥ Uo
 - Ii (or Imax) ≥ Io
 - Pi ≥ Po
 - Ci ≤ Co – Ccable
 - Li ≤ Lo – Lcable
4. FLXA202 Analyzer must be installed in accordance with one of the following:
 - a) in a SELV or PELV system, or
 - b) via a safety isolating transformer complying with the requirements of IEC 61558-2-6, or a technically equivalent standard, or
 - c) directly connected to apparatus complying with IEC60950 series, IEC61010-1, or a technically equivalent standard, or
 - d) fed directly from cells or batteries.
5. When FLXA202 Analyzer is installed with accompanying cable glands, cable with an external diameter of 6 mm to 12 mm must be used for field wiring. The cable glands must be secured with a tightening torque of 6 Nm so that they can be released only with the aid of a tool. Unused cable gland shall be sealed with the accompanying metal plug.

Rev. Doc.No.: NIE015-A71 P.2

Yokogawa Electric Corporation

(6) NEPSI and KOSHA Intrinsic safety “ia”
 (Refer to (1) ATEX and IECEx Control Drawing)

■ Model & Suffix Codes

Model	Suffix code	Option code	Description
FLXA202	2-Wire Analyzer
Power supply	-D	Always -D
Housing (Note 12)	-B -C -D	Aluminum alloy cast + urethane coating Aluminum alloy cast + epoxy coating Aluminum alloy cast + high anti-corrosion coating
Display(Note 13)	-D	Anti-glare LCD
Type(Note 1)	-AB -AD -AG -AQ -AR -CB -CD -CF -CG -CH -CQ -CR -DB -DD -DE	General purpose for CE, RCM General purpose for CSA General purpose for KC General purpose for EAC with PA General purpose for EAC IS for ATEX, IECEx (Note 14) IS for FM, CSA (Note 2) IS for TIIS (Note 15) IS for KOSHA (Note 3) IS for NEPSI IS for EAC with PA IS for EAC Type n for ATEX, IECEx NI for FM, CSA Type n for CSA
1st input	-P1 -C1 -C5 -D1 -S1	pH/ORP (Note 4) Conductivity (SC) Inductive conductivity (ISC) Dissolved oxygen (DO) pH/ORP (SENCOM sensor) (Note 5)
2nd input (Note 6)	-NN -P1 -C1 -D1	Without input pH/ORP (Note 4) Conductivity (SC) Dissolved oxygen (DO)
Output	-A	4-20 mA + HART
—	-N	Always -N
Language set (Note 7)	-LA	English and 11 languages
Country (Note 8)	-N -J	Global except Japan Japan
—	-NN	Always -NN
Option	Mounting hardware Hood Tag plate Conduit adapter(Note 10) Measurement law	/UM /U /PM /H6 /H7 /H8 /SCT /CB4 /CD4 /CF4 /CB5 /CD5 /CF5 /K	Universal mounting kit (Note 9) Pipe and wall mounting hardware Panel mounting hardware Hood, stainless steel Hood, stainless steel + urethane coating Hood, stainless steel + epoxy coating Stainless steel tag plate G1/2 x 3 pcs 1/2NPT x 3 pcs M20 x 1.5 x 3 pcs G1/2 x 3 pcs for Type n 1/2NPT x 3 pcs for Type n M20 x 1.5 x 3 pcs for Type n With Measurement Law certificate (Note 11)

Notes:

- Type “-C * ” is intrinsic safety (IS), Type “-DB” is type n of ATEX and IECEx, Type “-DD” is nonincendive (NI) of FM and CSA
Type “-DE” is type n of CSA.
- Type “-CD ” is intrinsic safety, but is available as nonincendive.
- Korean IM is attached to FLXA202 instead of English IM.
- This input is to be come from an analog pH/ORP sensor.
- When the analyzer is connected with the digital sensor (FU20F pH/ORP SENCOM Sensor)

-
- 6: When a 2nd input is selected, only the same kind of the 1st input is available.
For example, when a 1st input is "-P1", the 2nd input must be the same "-P1".
The combination of ISC and ISC is not available. And, the combination of SENCOM sensor and SENCOM sensor is not available, either.
 - 7: These languages are message languages on the analyzer's display.
One analyzer has English and 11 languages.
All languages are as follows; English, Chinese, Czech, French, German, Italian, Japanese, Korean, Polish, Portuguese, Russian and Spanish.
 - 8: When an analyzer is used in Japan, it must meet the Japanese Measurement Law, please select the "-J".
Only SI units must be used on the analyzer and its documents in Japan.
 - 9: The universal mounting kit contains the pipe and wall mounting hardware (/U) and the panel mounting hardware (/PM).
 - 10: "/CB5", "/CD5", "/CF5" are exclusively for type "-DB" or "-DE". "/CB4", "/CD4", "/CF4" cannot be used with type "-DB" or "-DE".
"/CB4", "/CD4", "/CF4" can be used with other types of the analyzer except for "-DB" or "-DE".
 - 11: The analyzer with Japanese Measurement Law certificate is available only for the following model;
FLXA202-D-[Housing code]-D-AB-P1-NN-A-N-LA-J-NN/[option code except /K]/K
Only one pH measurement with an analog sensor is certified. The digital sensor (FU20F) is not certified.
The output signal of 4 - 20 mA is certified. HART communication is not certified
 - 12: Urethane coating is for acid resistance, and epoxy coating is for alkali resistance. For high anti-corrosion coating, both urethane coating and epoxy coating are applied.
 - 13: Type "-CF" is anti-reflection coated. Other types are anti-glare coated.
 - 14: Product registration is done by Yokogawa Taiwan Corporation as an importer in Taiwan.
 - 15: For detailed information refer to Japanese GS 12A01A03-01JA.

■ Dimensions and Mounting

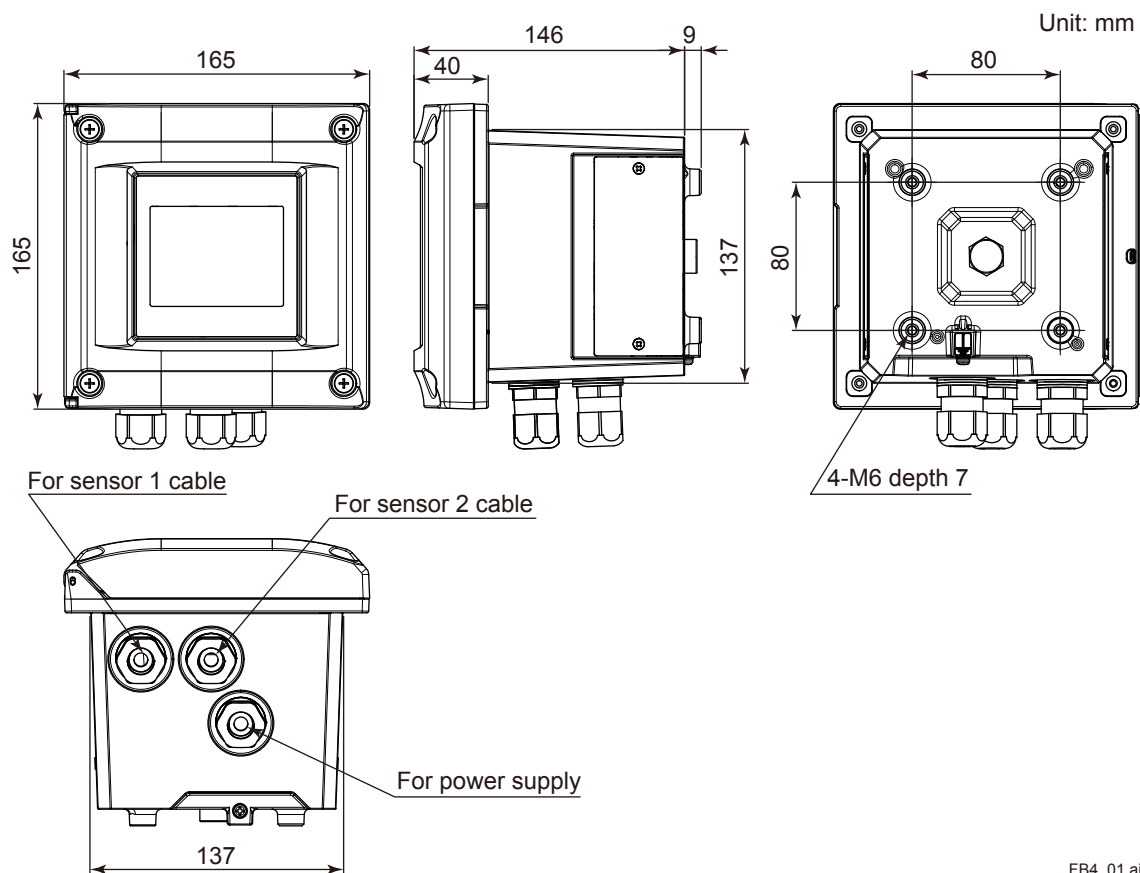

FB4_01.ai

Conduit Adapter (Option code: □/CB4, □/CD4, □/CF4)

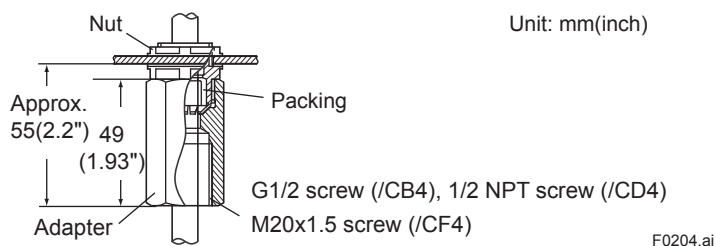

Conduit Adapter (Option code: □/CB5, □/CD5, □/CF5)

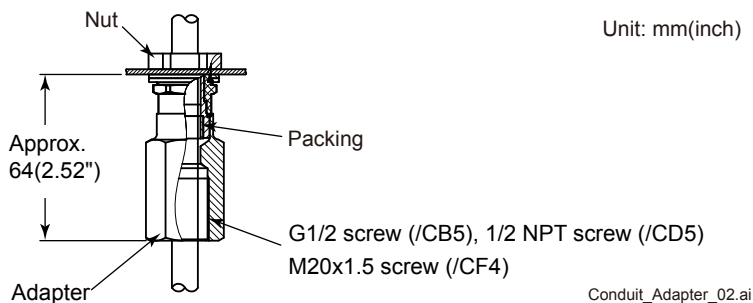

(Note) The universal mounting kit (/UM) contains the pipe and wall mounting hardware (/U) and the panel mounting hardware (/PM).

Panel mounting hardware (Option code: □/PM, □/UM)

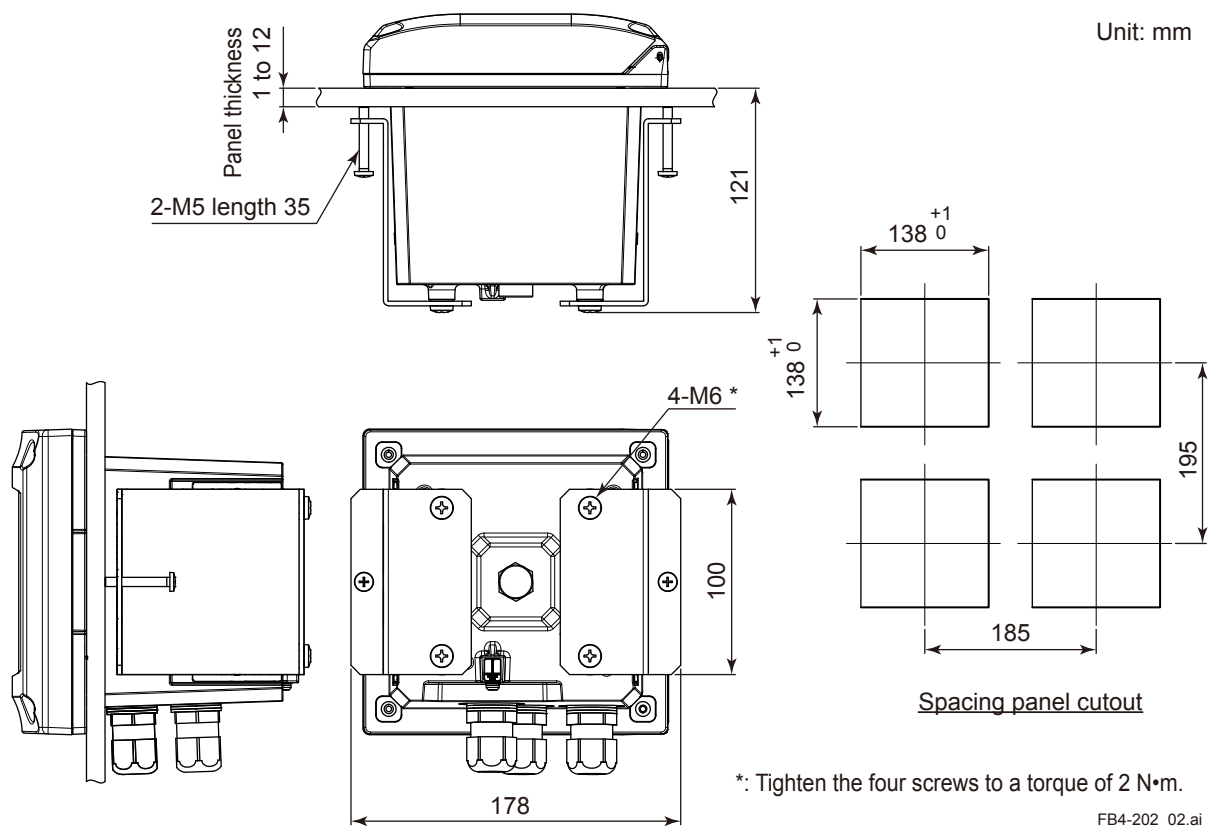

Wall mounting hardware (Option code: □/U, □/UM)

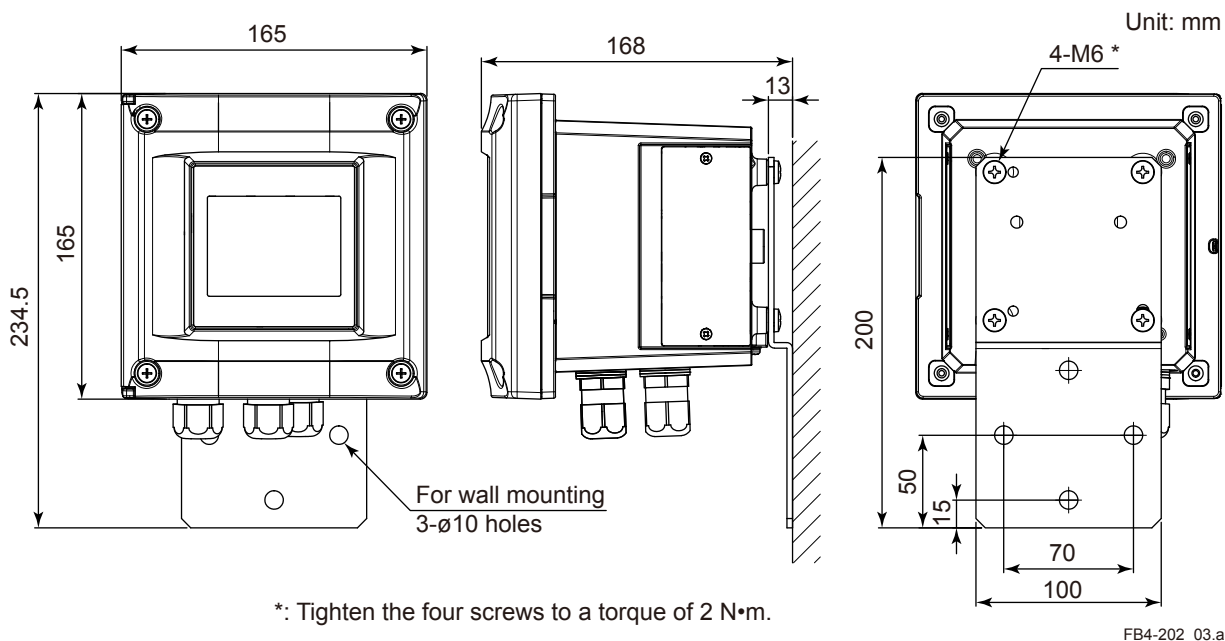

Note: The wall on which the analyzer is mounted should be strong enough to bear the weight of more than 8 kg.

Pipe mounting hardware (Option code: □/U, □/UM)

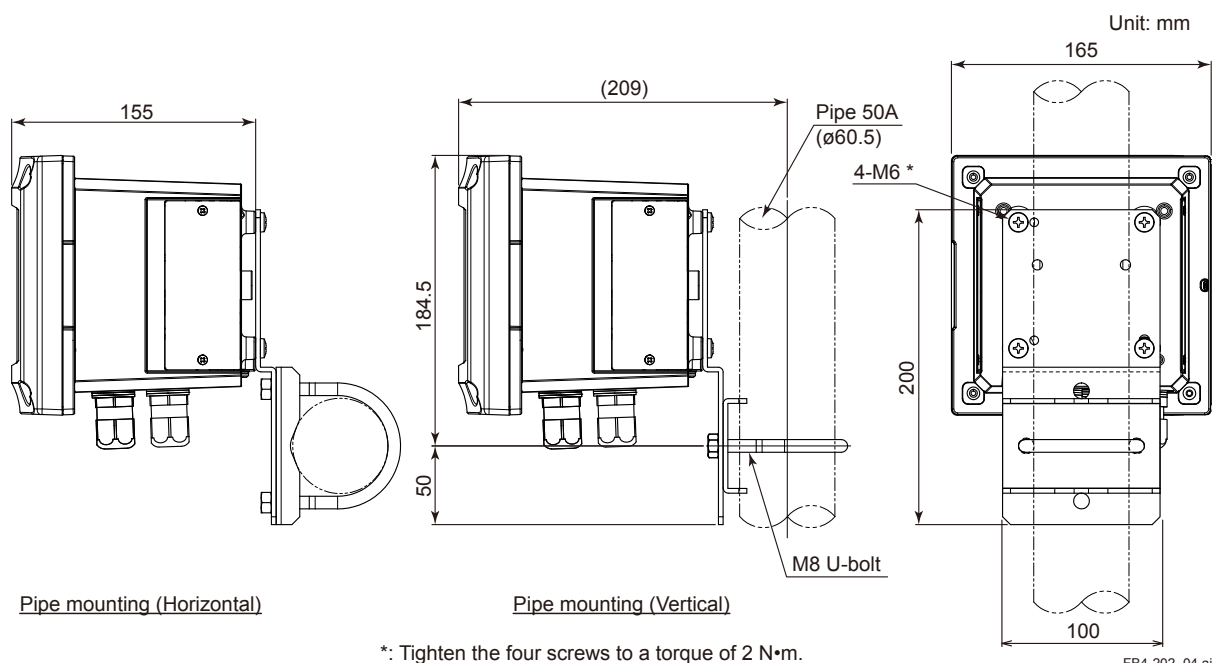

Stainless steel hood (Option code: □/H6, □/H7, □/H8)

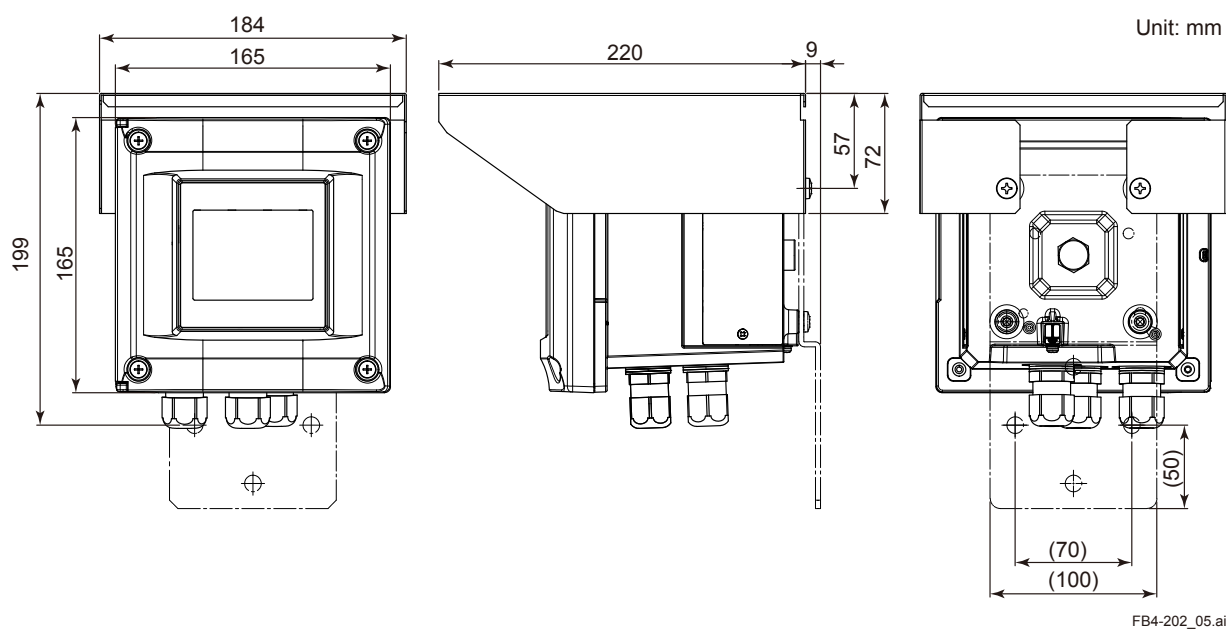

■ Wiring Diagrams

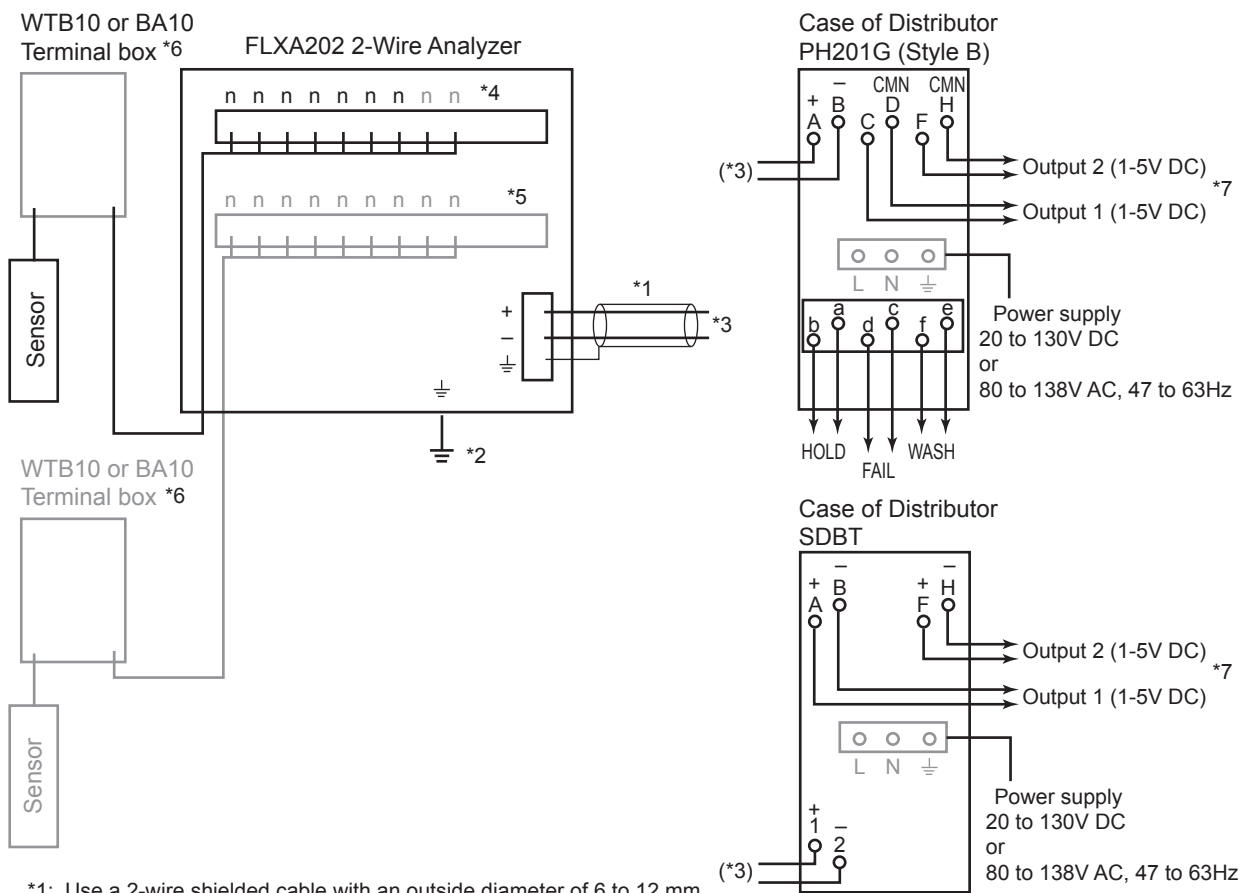

*1: Use a 2-wire shielded cable with an outside diameter of 6 to 12 mm.

*2: Connect the analyzer to ground. (Class D ground: 100 ohm or less)

*3: This line is connected to a distributor or 24V DC power supply.

*4: Terminal numbers for each sensor module are shown below.

*5: Two modules of the same kind of measurement/sensor type can be installed. When measuring inductive conductivity or pH/ORP with the SENCOM sensor, only one module can be installed.

*6: The terminal box may be necessary depending on the sensor cable length and the distance between the analyzer and the sensor.

The SENCOM sensor is to be connected directly to the analyzer without a terminal box.

*7: Two outputs, output 1 and output2, of PH201G or SDBT are same signals.

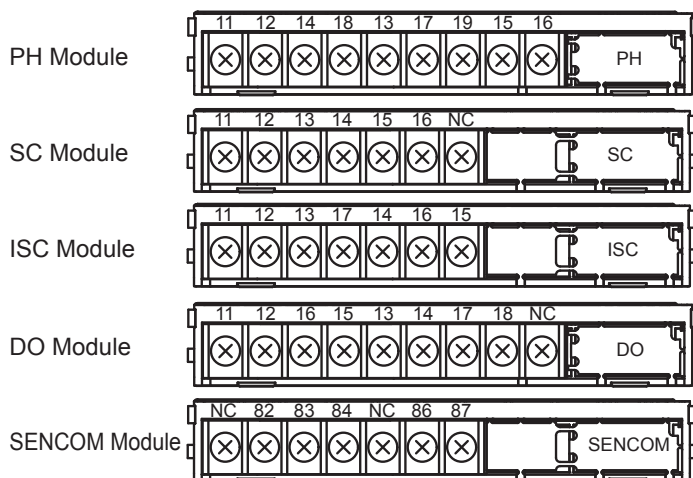

■ Inquiry Specifications Sheet for FLXA202 2-Wire Analyzer

Make inquiries by placing checkmarks (✓) in the pertinent boxes and filling in the blanks.

1. General Information

Company name _____
 Contact Person; _____ Department; _____
 Plant name; _____
 Measurement location; _____
 Purpose of use; Indication, Recording, Alarm, Control

2. Measurement Conditions

- (1) Process temperature; _____ to _____ Normally _____ [°C]
 (2) Process pressure; _____ to _____ Normally _____ [kPa]
 (3) Flow rate; _____ to _____ Normally _____ [l/min]
 (4) Flow speed; _____ to _____ Normally _____ [m/s]
 (5) Slurry or contaminants; No, Yes
 (6) Name of process fluid; _____
 (7) Components of process fluid; _____
 (8) Others;

3. Installation Site

- (1) Ambient temperature; _____ to _____ [°C]
 (2) Location; Outdoors, Indoors
 (3) Others;

4. Requirements

- 1st Input; pH/ORP (analog sensor) Conductivity (SC) Inductive conductivity (ISC)
 Dissolved oxygen (DO) pH/ORP (digital sensor, FU20F)
 2nd Input; With (same as 1st Input) Without

4.1 pH/ORP (analog sensor)

1st Input

- (1) Measuring range; pH 0 to 14 ORP _____ to _____ mV _____
 (2) Transmission output; 4 to 20 mA DC pH ORP Temperature
 (3) System configuration selection; Electrode, Holder, pH Converter, Cleaning system, Terminal box,
 Accessories
 (4) Electrode cable length; 3m, 5m, 7m, 10m, 15m, 20m, _____m
 (5) Electrode operating pressure; 10 kPa or less, More than 10 kPa
 (6) Type of holder; Guide pipe, Submersion, Flow-through, Suspension, Angled floating ball,
 Vertical floating ball
 (7) Cleaning method; No cleaning, Ultrasonic cleaning, Jet cleaning, Brush cleaning
 (8) Sample temperature; -5 to 105°C, -5 to 100°C, -5 to 80°C
 (9) Others;

2nd Input

- (1) Measuring range; pH 0 to 14 ORP _____ to _____ mV _____
 (2) Transmission output; 4 to 20 mA DC pH ORP Temperature
 (3) System configuration selection; Electrode, Holder, pH Converter, Cleaning system, Terminal box,
 Accessories
 (4) Electrode cable length; 3m, 5m, 7m, 10m, 15m, 20m, _____m
 (5) Electrode operating pressure; 10 kPa or less, More than 10 kPa
 (6) Type of holder; Guide pipe, Submersion, Flow-through, Suspension, Angled floating ball,
 Vertical floating ball
 (7) Cleaning method; No cleaning, Ultrasonic cleaning, Jet cleaning, Brush cleaning
 (8) Sample temperature; -5 to 105°C, -5 to 100°C, -5 to 80°C
 (9) Others;

4.2 Conductivity

1st Input

- (1) Measuring range; _____
- (2) Transmission output; 4 to 20 mA DC
- (3) Detector/sensor; SC4AJ Two electrode system (0.02 cm⁻¹) Two electrode system (0.1 cm⁻¹)
 SC8SG Two electrode system (0.01 cm⁻¹) Two electrode system (10 cm⁻¹),
 Four electrode system (10 cm⁻¹)
 SC210G Two electrode system (0.05 cm⁻¹) Two electrode system (5 cm⁻¹)
- (4) Detector/sensor mounting method;
 SC4AJ Adapter mounting, Welding socket, Welding clamp
 SC8SG Screw-in, Flow-through
 SC210G Screw-in, Flange, Flow-through, Screw-in with gate valve
- (5) Electrode cable length; SC4AJ 3m, 5m, 10m, 20m
 SC8SG 5.5m, 10m, 20m
 SC210G 3m, 5m, 10m, 15m, 20m
- (6) Others;

2nd Input

- (1) Measuring range; _____
- (2) Transmission output; 4 to 20 mA DC
- (3) Detector/sensor; SC4AJ Two electrode system (0.02 cm⁻¹) Two electrode system (0.1 cm⁻¹)
 SC8SG Two electrode system (0.01 cm⁻¹) Two electrode system (10 cm⁻¹),
 Four electrode system (10 cm⁻¹)
 SC210G Two electrode system (0.05 cm⁻¹) Two electrode system (5 cm⁻¹)
- (4) Detector/sensor mounting method;
 SC4AJ Adapter mounting, Welding socket, Welding clamp
 SC8SG Screw-in, Flow-through
 SC210G Screw-in, Flange, Flow-through, Screw-in with gate valve
- (5) Electrode cable length; SC4AJ 3m, 5m, 10m, 20m
 SC8SG 5.5m, 10m, 20m
 SC210G 3m, 5m, 10m, 15m, 20m
- (6) Others;

4.3 Inductive conductivity

- (1) Measuring range; _____
- (2) Transmission output; 4 to 20 mA DC
- (3) System configuration selection; ISC40GJ Sensor, Holder, Converter, BA20 Terminal box,
 WF10J Extension cable
- (4) Sensor mounting method; ISC40FDJ Immersion holder, ISC40FFJ Flow-through holder,
 ISC40FSJ Direct insertion adapter
- (5) ISC40GJ Sensor cable length; 5m, 10m, 15m, 20m
- (6) WF10J Extension cable length; 5m, 10m, 20m, 30m, 40m
- (7) Others;

4.4 Dissolved oxygen

1st Input

- (1) Measuring range; 0 to 50 mg/L _____
- (2) Transmission output; 4 to 20 mA DC
- (3) System configuration selection; Electrode, Holder, Converter, Cleaning system,
 Terminal box, Maintenance parts set, Calibration set
- (4) Electrode cable length; 3m, 5m, 10m, 15m, 20m
- (5) Type of holder; Guide pipe, Submersion, Flow-through, Suspension,
 Angled floating ball, Vertical floating ball
- (6) Cleaning method; No cleaning, Jet cleaning
- (7) Others;

2nd Input

- (1) Measuring range; 0 to 50 mg/L _____
- (2) Transmission output; 4 to 20 mA DC
- (3) System configuration selection; Electrode, Holder, Converter, Cleaning system,
 Terminal box, Maintenance parts set, Calibration set
- (4) Electrode cable length; 3m, 5m, 10m, 15m, 20m
- (5) Type of holder; Guide pipe, Submersion, Flow-through, Suspension,
 Angled floating ball, Vertical floating ball
- (6) Cleaning method; No cleaning, Jet cleaning
- (7) Others;

4.5 pH/ORP (digital sensor, FU20F)

- (1) Measuring range; pH 0 to 14 ORP _____ to _____ mV _____
- (2) Transmission output; 4 to 20 mA DC pH ORP Temperature
- (3) System configuration selection; Electrode, Holder, pH Converter, Cleaning system, Accessories
- (4) Electrode cable length; 3m, 5m, 10m, 20m, _____m
- (5) Electrode operating pressure; 10 kPa or less, More than 10 kPa
- (6) Type of holder; Guide pipe, Submersion, Flow-through, Suspension, Angled floating ball,
 Vertical floating ball
- (7) Cleaning method; No cleaning, Jet cleaning
- (8) Sample temperature; -5 to 105°C, -5 to 100°C, -5 to 80°C
- (9) Others;