

Input: 0-2 Amps AC to 0-200 Amps AC
Output: 4-20 mADC

- 4-20 mA Powered, Isolated Output
- CTX-ACR True RMS for Distorted Waveforms
- CTX-AC for Sinusoidal Waveforms
- Jumper Selectable Ranges

Applications

- Convert Amps to a DC Process Signal
- Monitor Current Ranges
- Monitor Motors, Pumps, Heaters

AC Current Input Ranges

See table at right, ranges are jumper selectable

Output

Loop-powered, 4-20 mA DC, 23 mA DC over range limit

Loop Power

12 VDC to 40 VDC max.

$$V_L = 12 \text{ VDC} + (R_L \times 0.020 \text{ A})$$

$$R_L = (V_L - 12 \text{ VDC}) \div 0.020 \text{ A}$$

Where: V_L = Loop Voltage (40 VDC max.)

R_L = Loop Resistance

Accuracy

±0.8% full scale

Response Time

600 milliseconds (to 90% step change)

Frequency Range

10 to 400 Hz

Isolation Voltage

UL listed to 1270 VAC, tested to 5000 VAC

Sensing Aperture

0.85" x 0.85" square (21.5 mm x 21.5 mm)

Housing

UL 94V-0 flammability rated

Environmental

-4 to 122 °F (-20 to 50 °C), 0-95% RH, non-condensing

Listings

UL & CUL 508 industrial control equipment
 CE certified

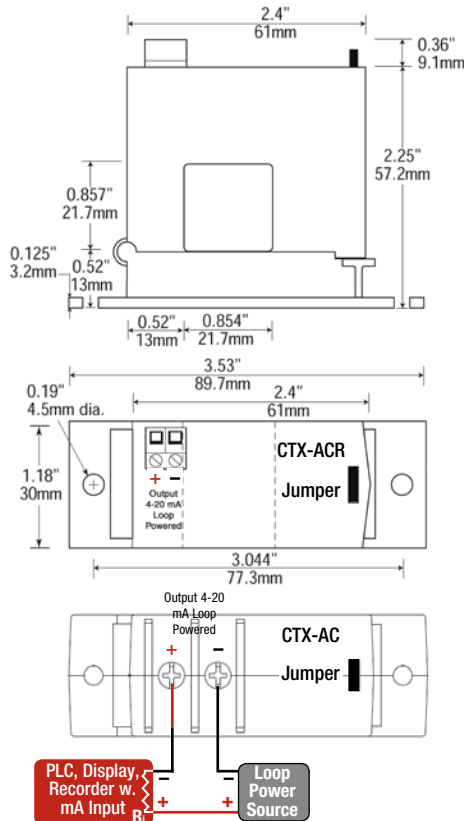

Models	Ranges	Maximum Current		
		Cont.	6 Sec	1 Sec
CTX-AC-0	0-2 A	80 A	125 A	250 A
CTX-ACR-0 (True RMS)	0-5 A	100 A	125 A	250 A
CTX-AC-1	0-10 A	80 A	125 A	250 A
	0-20 A	110 A	150 A	300 A
	0-50 A	175 A	215 A	400 A
CTX-AC-2	0-100 A	200 A	300 A	600 A
	0-150 A	300 A	450 A	800 A
	0-200 A	400 A	500 A	1000 A

Description

The split-core CTX-AC and CTX-ACR series transmitters measure AC current in ranges up to 200 Amps AC and convert it to an isolated, loop-powered, 4-20 mA DC output. These two-wire transmitters consist of a current transformer and a signal conditioner in one compact package.

The CTX-AC is an economical solution where sinusoidal or undistorted wave forms are encountered, such as resistive loads.

The true RMS output CTX-ACR series transmitters can be used for both linear (sinusoidal) or non-linear (distorted) waveform applications. The CTX-ACR incorporates a mathematical algorithm that integrates the AC current waveform over time and provides an output equal to the true RMS value of the waveform. The true RMS output ensures accurate measurements in electrically noisy environments and distorted sine waves from variable frequency drives (VFDs) or SCRs.

The transmitters are designed to withstand harsh industrial environments and can be mounted in virtually any position.

Only two wire connections are necessary for the 4-20 mA DC output. Power is derived from the output loop eliminating the need for additional power wiring.

Instructions

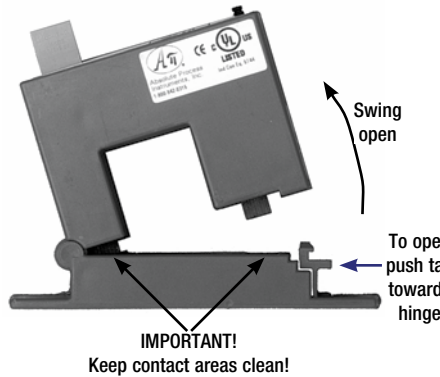

Electrical Connections

WARNING! Turn all power off before connecting or disconnecting wiring, or removing or installing transmitter.

See wiring diagrams. All wiring must be performed by a qualified electrician or instrumentation engineer. Consult factory for assistance.

Polarity must be observed for output wiring connections. If the output does not function, check wiring and polarity.

Range Selection

CTX-AC and CTX-ACR series transducers feature field selectable ranges. The sensing range is jumper configurable as indicated on the product label. The ranges are factory calibrated.

- Determine the normal operating amperage of your monitored circuit.
- Select the range that is equal to or slightly higher than the normal operating amperage.



Quick Link
api-usa.com/current



- Place the range jumper in the appropriate position.
 CTX-AC-0 and CTX-ACR-0

- Low range Jumper to "Mid" position
- High range Jumper to "High" position

CTX-AC-1, CTX-ACR-1, CTX-AC-2, CTX-ACR-2

- Low range No jumper
- Mid range Jumper to "Mid" position
- High range Jumper to "High" position

Installation

Press the tab in the direction as shown to open the sensor.

Place wire in opening, press the hinged portion firmly downward until a definite click is heard and the tab pops out fully.

Mounted in any position or hang directly on wires with a wire tie. Leave at least one inch distance between sensor and other magnetic devices.

KEEP SPLIT-CORE CONTACT AREAS CLEAN!

Silicone grease is factory applied on the mating surfaces to prevent rust and improve performance. Do not allow grit or dirt onto the grease in the contact area. Operation can be impaired if the mating surfaces do not have good contact. Check visually before closing.

Output Wiring

Connect wires to the sensor being careful to observe correct wiring polarity as shown in the wiring diagram.

Use up to 14 AWG solid or stranded copper wire and tighten CTXAC terminals to 3.5 inch-pounds torque and the CTX-ACR terminals to 5 inch-pounds torque.

Be sure the output load or loop power requirements are met according to the formula in the specifications.

Troubleshooting

- No 4-20 mA output**
 - A. Loop power supply is not properly sized. Check loop power supply voltage and current rating.
 - B. Wiring polarity is incorrect. Check and correct wiring polarity according to wiring diagram.
 - C. The core contact area may be dirty. Open the sensor and clean the contact area.
- 4-20 mA output signal too low**
 - A. The jumper may be set in a range that is too high for current being monitored. Move jumper to a lower range.
 - B. Monitored current is below minimum required. Loop the monitored wire several times through the aperture until the sensed current rises above minimum. Sensed Amps = (Actual Amps) x (Number of Loops). Count loops on the inside of the aperture only.
- Output is always at 4 mA**
 - A. Monitored load is not AC or is not on. Check that the load is AC and that it is actually on.
- Output is always at 20 mA**
 - A. The jumper may be set in a range that is too low for current being monitored. Move jumper to the correct range.