



Totalizes running time of electrically operated equipment... synchronous motor driven models for display of hours, minutes, or seconds



6

ELECTRIC
TIMERS

The HK5 series totalizes the "ON" or running time of electrically operated equipment. Its features include:

- Large, easy to read digits
- Dust proof dial cover
- Maintenance free
- High impact plastic case
- Can be mounted in any position

OPERATION

The Eagle Signal brand HK5 series time totalizer has a synchronous motor which drives a set of digit readout wheels to indicate the total time the unit is energized. Six digit-wheels, including a 1/10 digit on hours and minutes, provide a fine, wide range of time measurement. The HK5 features a front mounted reset wheel. It can be reset to zero at any time during its operation.

SPECIFICATIONS

Time Ranges:
Non-Reset

Sym.	Time Range
HK400	99999.9 Min.
HK410	99999.9 Hr.
HK420	999999 Sec.

Reset

Sym.	Time Range
HK500	9999.9 Min.
HK510	9999.9 Hr.
HK520	99999 Sec.

Voltage/Frequency: 120V (+10, -15%), 50/60 Hz
240V (+10, -15%), 50/60 Hz

Burden: 3W max.

Temperature Range: 0° to 140°F (-17° to +60°C)

Agency Approvals: UL Recognition E59290
CSA Certification LR27967

MOUNTING

Requires 2 3/8 diameter panel cutout for mounting. 1/2 maximum mounting panel thickness.

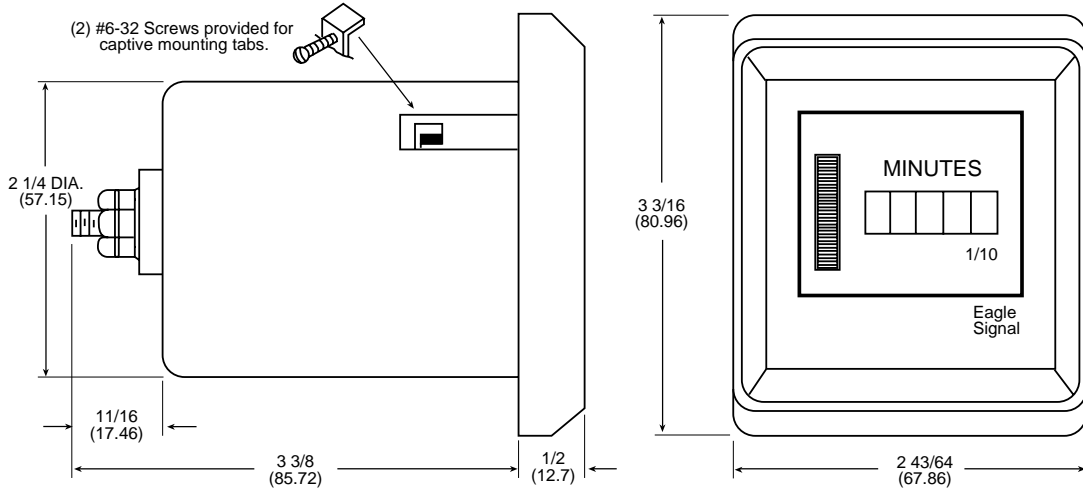

CAUTION: When resetting the HK5 unit, adjust odometer to position 00000 at top of window, as shown.

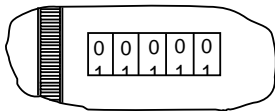

- Typical Applications:**
- Electronic Equipment
 - Computers and Office Machines
 - Machine Tool Lubrication
 - Maintenance Programs
 - Industrial Ovens
 - Electrical Equipment Rental
 - Industrial Cost Analysis
 - Nuclear Control Systems
 - Recording Machine Down Time
 - Radio Transmitters

ENCLOSURES

Model No.	Description
1701-0673	Surface Mounting Box NEMA 1

ACCESSORIES

Model No.	Description
HK500-07	Key Lock Cover

ORDERING INFORMATION

Consult Customer Service for availability of other voltages and frequencies.

